

COMMERCIAL FIRE SPRINKLER REQUIREMENTS
UNDERGROUND FIRE LINES, ON-SITE FIRE SERVICE &
OVERHEAD FIRE SPRINKLER SYSTEMS

This information package shall be used in conjunction with NFPA 13, 13R, 24, and other applicable NFPA design standards as adopted by the City of Mountain View, for commercial buildings, R-1 and R-2 Occupancies. (Refer to the California Fire Code (CFC) for adopted editions of NFPA). This information package is not intended for use as a stand-alone document.

ADMINISTRATIVE:

- Submittals are only accepted online via ePermitsMV. To submit please visit the following for instructions on submitting:
<https://www.mountainview.gov/depts/comdev/building/epermitsmv.asp>
- **Provide associated building permit number on permit application if applicable.**
- Plan check turnaround time for each submittal is a **minimum** of three (3) weeks.
- Underground fire permits and fire sprinkler submittals with less than 20 heads being added or altered may be scheduled for a One-Stop review. Please visit the following the schedule a Fire One-Stop Appointment: <https://building.timetap.com/#/>
- Incorporate onto the drawings: the contractor's name, address, phone number, California Contractor's license number and license type or P. E. license number.
- Field inspections are conducted Monday, Wednesday and Friday only. For inspection scheduling or for general information please call (650) 903-6313. Inspections will not be scheduled until a permit has been issued. **Allow 2-3 working days' advanced notice when requesting inspections.** The permit card and approved set of plans must be kept at the project site until the permit is finalized. Failure to maintain the permit card and approved plans on site will result in the cancellation of the inspection.
- System equipment and piping shall not be installed prior to issuance of a permit.
- The minimum scale for overhead fire sprinkler plans is 1/8" = 1'-0". In addition, plans and pipe lengths shall be fully dimensioned to coincide with the specified scale.
- All fire sprinkler submittals requiring hydraulic calculations shall include a copy of the City of Mountain View Fire Flow Data Form. In addition, fire flow data shall include the elevation of the tested hydrant in relation to the base of the sprinkler riser. Fire Flow Data Forms shall be obtained from the City of Mountain View Water Division at (650) 903-6329. Fire flow data shall not be older than 12 months from date of test to date of application.

UNDERGROUND FIRE LINES AND ON-SITE FIRE SERVICE

1. The underground fire line shall be designed and installed in accordance with the City of Mountain View Requirements, NFPA 13, 24 and other applicable NFPA Standards as adopted by the City of Mountain View. *Incorporate this as a verbatim note onto the drawings.*
2. The color of the post indicator valve (PIV) and fire department connection (FDC) shall be red. The fire department connection shall be provided with two (2) horizontal rows of 3-inch-wide highly **reflective tape**, spaced 3" apart, and placed on the upper portion of the fire department connection riser. On-site fire hydrants shall be painted safety yellow. Wharf hydrants shall be painted red. *Incorporate as a note on the drawings or provide in a detail.*
3. All underground fire lines and hydrants shall be flushed using the velocities specified in NFPA 24 prior to any overhead pipe being connected. Contractors shall have the appropriate tools and equipment on-site to complete a flush of all piping and hydrants. There shall be sufficient fire hose to direct the water to a safe location off the site. In the case of multiple hydrants or risers, a minimum of two (2) appurtenances shall be connected and ready to flush. A minimum of two (2) replacement hoses, along with additional burlap sacks, shall be available on site. *Incorporate the following flush arrangements as verbatim notes onto the drawings.*
 - 4" pipe shall be flushed through a minimum of one (1) 4" hose or two (2) 2 1/2" hoses.
 - 6" pipe shall be flushed through a minimum of one (1) 4" hose or four (4) 2 1/2" hoses.
 - 8" pipe shall be flushed through a minimum of two (2) 4" hoses; one (1) 4" hose and two (2) 2 1/2" hoses; or six (6) 2 1/2" hoses.

NOTE: Fire hydrants shall be flushed using the hose arrangement required for 6" pipe. Wharf hydrants shall be flushed using the hose arrangement required for 4" pipe.

4. A hydrostatic test at 200 psi for two hours is required. This test shall be witnessed by the Fire Protection Engineer prior to covering the pipe. Center loading is permissible. *Incorporate as a verbatim note onto the drawings.*
5. Backflow prevention shall be installed on the address side of the building in accordance with the City of Mountain View Public Works Standard Provisions. The applicable Double Check Detector Assembly (DCDA) *shall be incorporated onto the drawings.* Each OS&Y valve shall have a sign indicating the address(es) and system(s) served. See attached sign examples.
6. The Double Check Detector Assembly (DCDA) shall be an approved model on the Mountain View Public Works Standard Provisions. Approved fire service DCDA's include the following models for sizes between 4" and 10": *Febco LF876V, Wilkins 350DA, and Wilkins 450DA.*

Exception: When a Class 3 or Class 4 fire service incorporates the use of chemicals in the fire prevention systems or connects to a nonapproved auxiliary water source, the backflow prevention assemblies shall be a Reduced Pressure Detector Assembly (RPDA). Approved reduced pressure detector backflow prevention assemblies include the following models for sizes between 4" and 10": *Febco LF860, Wilkins 375 DA, and Wilkins 475 DA*

7. The fire department connection (FDC) post indicator valve (PIV) and wharf hydrant shall be provided with an all-weather sign indicating the address (es) and system components served. (i.e. auto sprinkler, on-site hydrant, and wharf hydrant). The FDC shall be provided with frangible metal caps or brass plugs. Plastic caps are not permitted. Incorporate a sign detail for each FDC and PIV

onto the drawings. See attached sign examples: The Wharf hydrant sign shall state what FDC it is served by.

8. Civil drawings are not construed as underground fire line drawings and will not be accepted for review.
9. Indicate the proposed occupancy classification and sprinkler design density for the building.
10. When required, on-site wharf hydrants shall consist of two (2) 2-1/2" hose valve outlets capable of supplying 500 gallons per minute with both outlets flowing. Hose valve outlets shall be listed for exterior use and provided with a 1-1/8" pentagonal operating nut. Hose valve outlets shall be provided with 2 1/2" NSH male threads with brass caps and chains. Submittals shall include complete manufacturer specifications for the proposed hose valve outlets. See attached installation detail.
NOTE: On-site wharf hydrants and/or on-site City standard hydrants may be required when the building(s) is located in excess of 150' from an approved vehicular access roadway or fire hydrant, or the building(s) is not protected with automatic fire sprinklers.
11. Indicate the size of the city main.
12. Indicate the type and size of all underground pipe and fittings. Type shall include class of pipe, class of fittings and pressure rating.
13. Indicate the method of restraining the underground piping (i.e. thrust blocks, rods etc.).
14. Provide complete calculations for sizing of thrust blocks (height and width) and specify rod diameters and clamp sizes in accordance with NFPA 24 and NFPA 13. Thrust block calculations shall use a soil bearing strength of 1000 psf.
15. Indicate the location and type of all above and below grade valves. All fire sprinkler risers shall be provided with above grade, exterior, indicating control valves located at the DCDA. When multiple sprinkler risers, on-site hydrants, wharf hydrants, or a combination thereof are supplied from the same underground fire line, additional above grade, exterior, indicating control valves shall be installed to facilitate shutting down individual fire sprinkler risers without shutting off other risers, on-site hydrants or wharf hydrants.
16. Sectional control valves (PIV) shall be provided for looped underground fire lines and for fire lines served by more than one water service connection. Post indicator valves shall be used whenever sectional control valves are required. The fire sprinkler monitoring system shall electrically monitor all sectional control valves.
17. Indicate the depth of pipe bury and the type of backfill materials used.
18. Backfill shall consist of clean fill sand or pea gravel to a minimum of 6" below and to a minimum of 12" above the pipe, and shall contain no ashes, cinders, refuse, organic matter, or other corrosive materials.
19. Provide a detail of the pipe transition from the horizontal run of pipe to the vertical. (i.e. at base of riser or base of hydrant).
20. Listed plastic pipe (AWWA C900) shall not be subject to building foundation/footing loads. When using listed plastic pipe a transition to ductile iron shall be made a minimum of 5 ft from the building

or edge of slab. Show the method of protecting the pipe (i.e. sleeve, annular clearance) when ductile iron pipe runs under or through the building slab/footing.

21. Pipe installed under the buildings or building foundations shall not contain mechanical joints.
22. The FDC shall be within 100' of a fire hydrant. The fire hydrant shall be on the same side of the street as the FDC.

OVERHEAD SPRINKLER SYSTEM

23. The sprinkler system shall be designed and installed in accordance with the City of Mountain View Requirements, NFPA 13 and other applicable NFPA Standards as adopted by the City of Mountain View. *Incorporate as a verbatim note onto the drawings.*
24. Plan submittals for overhead systems shall include working underground drawings. Underground drawings "By Others" shall be submitted for review and permit prior to approval of the overhead plans.

NOTE: A permit will not be issued for the overhead system until such time as the underground system has been permitted.

25. All system equipment and components shall be listed/approved for its intended use.

NOTE: The City of Mountain View reserves the right to not approve a listed component or piece of equipment due to past performance.

26. All welded pipe and welded outlets shall be inspected by the Fire Protection Engineer prior to pipe installation. *Incorporate as a verbatim note onto the drawings.*
27. All new system installations shall be hydrostatically tested at 200 psi for two hours. Alterations to existing systems shall be hydrostatically tested at a minimum of 175 psi for two hours. *Incorporate as a verbatim note onto the drawings.*

NOTE: This test is generally not required when only adding 1" armovers and drops from existing outlets. A hydrostatic test may be required for extensive alterations, the addition of new supply mains, or when a new system is connected to an existing system.

28. Provide a full height section view of the area of work and include the size and type of all ceiling and roof construction members. Note: Areas of special consideration such as soffits, multiple ceiling heights or obstructions shall be clearly detailed.
29. Fire sprinkler systems shall drain to the sanitary sewer system.
30. Clearly indicate the sprinkler deflector distance criteria used.
31. Provide a key/site plan showing the location of the work in relation to the entire building/site.
32. Provide a riser detail for all new installations and for tenant improvement work requiring hydraulic calculations.
33. Indicate the type, schedule, diameter and C-factor of all piping.

34. Indicate the specific type of fittings used.
35. Provide complete pipe hanger details. Indicate the type of hanger used the size of all hanger rods, and the size and type of hanger fasteners, and structural member to be attached to. TZ anchor must be used on cracked concrete.
36. Indicate the manufacturer, model, orifice size, K-factor and temperature rating of all sprinklers. Submit a manufacturer's specification sheet for **all** sprinklers other than standard 1/2" commercial sprinklers.
37. Provide complete sway brace details. Information shall include: seismic bracing calculations using the zone of influence method; the size and type of brace material; size and type of fastener; method of attachment to the building structure (including size of the roof structural member); method of brace attachment to the sprinkler pipe; the angle of the brace and the orientation of the brace to the connecting surface. Brace locations shall be clearly identified on the drawings.

NOTE: NFPA 13 requires connections to wood to be made with through bolts, with a nut and washer on each end.

38. The Seismic Horizontal Force F_{pw} shall be calculated using the C_p values as follows:
 - a. Zip Code 94043: $C_p = 0.77$
 - b. Zip Code 94041: $C_p = 0.80$
 - c. Zip Code 94040: $C_p = 0.96$
39. Provide complete restraint of branchline details. Indicate the approved method, maximum spacing and locations on plans.
40. Sprinkler tenant improvement work will require existing hangers, branchline restraints and sway bracing to be upgraded within the area of work to comply with NFPA 13 as adopted by the City of Mountain View.
41. Trapeze hangers constructed of wood shall not be permitted unless certified by a structural engineer in accordance with the requirements of NFPA 13.
42. An armover detail shall be provided to clearly indicate the method of tie-in for new/relocated sprinklers and the locations of pipe hangers.
43. An approved Central Station, Remote Station or Proprietary Station, in accordance with NFPA 72, shall electrically monitor all automatic sprinkler system control valves and water flow switches as per California Fire Code.

NOTE: A permit is required for all associated monitoring equipment. Obtain a copy of the Fire Alarm and Sprinkler Monitoring requirements from the City of Mountain View Building Inspection Division.

44. A waterflow alarm bell shall be provided on the exterior of the building, visible from the street, and a horn on the inside of the building in a normally occupied area on each floor. Identify the location of notification devices on the drawing. The exterior bell shall have a sign: "Sprinkler Call 911"
45. Hydraulic calculations shall include the system hazard classification, design criteria, hydraulic summary, water supply curve with the system demand clearly plotted, flow schematic for grid systems and manufacturer friction loss curves for all detector check/backflow devices. Design area

reductions for quick response sprinklers shall apply only to light hazard occupancies as per CSFM amendments.

46. New commercial and industrial buildings shall be designed for not less than Ordinary Hazard Group 2 over the hydraulically most remote 1,500 square foot area.
47. A 10% safety factor (available supply versus required supply) shall be provided for all hydraulic calculations and shall be indicated on the supply curve. Note: The total flow, including inside and outside hose demands, shall be indicated as the total required supply.
48. Alterations to existing systems may be subject to new hydraulic calculations. Tenant improvement submittals shall include:
 - Calculated systems shall include the design criteria of the existing system (hazard classification and density/area), the size of all existing mains and typical pipe sizes for existing branchlines/gridlines in the project area. New piping may be sized in relation to the existing system when the area of work is of equivalent or less hazard.
 - Pipe schedule systems shall identify the pipe sizing back to the main riser and sprinkler head counts for all existing lines and mains serving the project area.
49. When a "shell only" system is submitted for permit and tenant improvement work is not a part of the submittal, the shell sprinklers shall maintain proper deflector distances. In addition, "shell only" systems shall be provided with 1" plugged outlets to accommodate future tenant improvements. All "Shell Only" systems shall use sprinklers of a minimum intermediate temperature.
50. Areas beneath raised floors will require automatic fire sprinklers when any of the following conditions are present: combustible construction materials, combustible storage, or contain any materials where the exposed surfaces have a flame spread rating greater than 25. The business owner or tenant shall provide a letter to the City of Mountain View indicating that all materials located within the raised floor space will comply with all identified limitations and restrictions.
51. Double interlock preaction systems shall only be installed in areas requiring protection from freezing.
52. Praction fire alarm panels shall be installed adjacent to and outside of the main entrance door of the protected room. The preaction fire alarm panel shall be separate and independent from any clean agent system installed inside the same room. When the preaction system riser is not installed within the area(s) served by the preaction system, a means of manual actuation shall be provided within each area protected by the preaction system.
53. All mechanical, electrical, and plumbing shall be installed prior to a rough visual and hydro inspection.
54. A hydraulic calculation nameplate, including pressure and flow at the base of riser and at the water source identified in the calculation. Placard information shall be stamped into the plate, labels or markers shall not be acceptable.
55. Submitted drawings shall include a detail of the general information sign and hydraulic design information sign; with all relevant information included on the detail.
56. Secondary Power Supply for Electrical Fire Pumps – Starting January 01, 2020, all new electric motor driven fire pump installations shall be provided with a backup generator as a secondary source, in which case the fire pump controller must be equipped with an automatic transfer switch.

57. Fire sprinklers are required to be provided within “phone booths”, or temporarily occupied enclosures that are required to be seismically attached to the structure.
58. All new parking garages required to be provided with a fire sprinkler system shall be designed to Ordinary Hazard (Group 2).
59. Car Stackers with One Lift Platform: Where car stackers/lifts occur within a garage area, the stackers shall be protected with an automatic wet sprinkler system designed to Extra Hazard (Group 2). Non-extended coverage standard-response sidewall sprinklers shall be used for coverage underneath the lift platform and shall be shielded from spray from above or be of the intermediate level/rack storage type. Each sidewall sprinkler shall cover a maximum area of 80 square feet. The hydraulic calculation design criteria shall include all ceiling-level sprinklers within a minimum 2,500 square foot area of sprinkler operation, or the maximum area containing car stackers and extending 15 feet into adjacent area that do not contain car stackers. The sidewall sprinklers are not required to be included in the area of operation.
60. Car Stackers with Two or more Lift Platforms: Parking garage areas containing car stacker with two or more vertical lift platforms (vehicles can be stacked 3 or more high) shall be protected with an automatic wet sprinkler system designed to the same requirements as above for a Single Lift Platform. The hydraulic calculation design criteria shall include all ceiling-level sprinklers within a minimum 2,500 square foot area of sprinkler operation, or the maximum area containing car stackers and extending 15 feet into the adjacent areas that do not contain car stackers. In addition, a total of six sidewall sprinklers under the lift platforms shall be included in the area of sprinkler operation. The design density for the sidewall sprinklers shall be Ordinary Hazard (Group 2). The sidewall sprinkler flow shall be from the two sidewall sprinklers covering under the top-level parking platform at three adjacent stalls or areas with car stackers.

ON-SITE WHARF HYDRANT SPECIFICATIONS

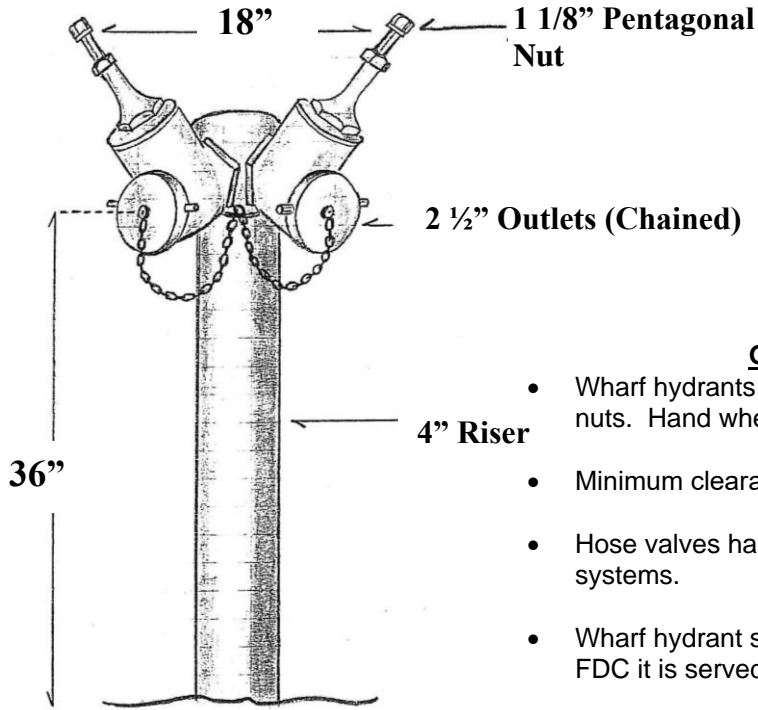

General Provisions

- Wharf hydrants shall be provided with 1 1/8" pentagonal nuts. Hand wheels are not acceptable.
- Minimum clearance between operating nuts is 18"
- Hose valves shall be listed for exterior use in wet-pipe systems.
- Wharf hydrant shall be provided with sign indicating which FDC it is served by.

SIGN EXAMPLES

PIV Controls ASR,
Standpipe and
On-Site Hydrant for
2000 Example Way

48 Minimum
Font Size

FDC Supplies ASR's
and Wharf Hydrants
for 100, 110 and 120
Sample Street

General Provisions

- Text shall content with background color.
- Each PIV FDC and wharf hydrant shall have a sign. For example, additional signs would be required for the site PIV for each riser at 100, 110 and 120 Sample Street.

Wharf Hydrant
Supplied by FDC on:
2000 Example Way

Text shall contrast with background color.

Each PIV and FDC shall have a sign. For example, additional signs would be required for the site PIV and the PIV for each riser at 100, 110 and 120 Sample Street.

SIGN EXAMPLES

POST INDICATOR VALVE DETAILS (Not to scale)

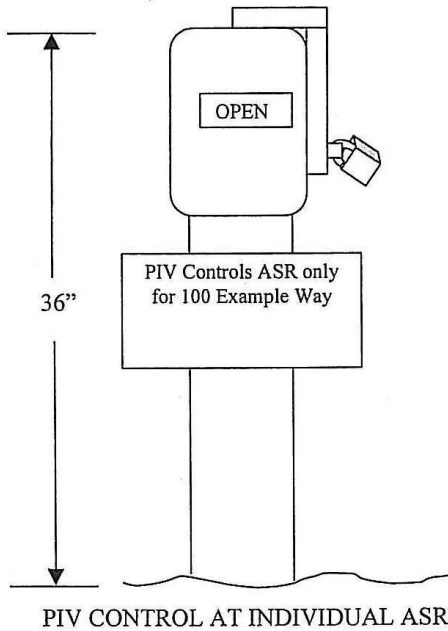
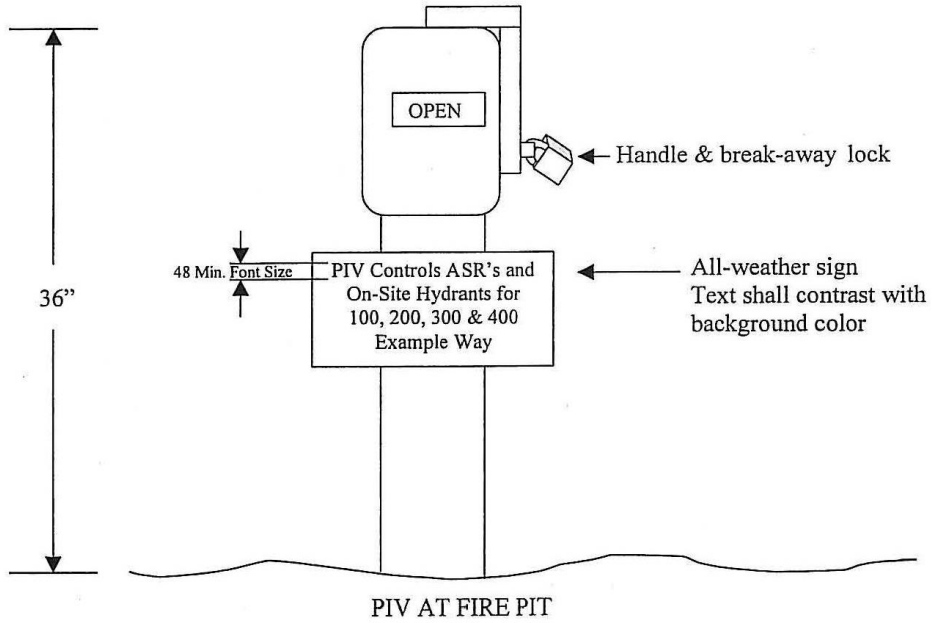

General Provisions

1. PIV's shall be provided with handles and break-away locks.
2. PIV's shall be provided with all-weather signs.
3. Signs shall indicate systems served (i.e. – ASR's, standpipes, on-site hydrants, wharf hydrants).
4. Exterior, above-grade, indicating control valves shall be provided for each automatic sprinkler system riser so that the water supply remains in service for other systems supplied when any one automatic sprinkler riser is shut down.

SIGN EXAMPLES

FIRE DEPARTMENT CONNECTION DETAILS (Not to scale)

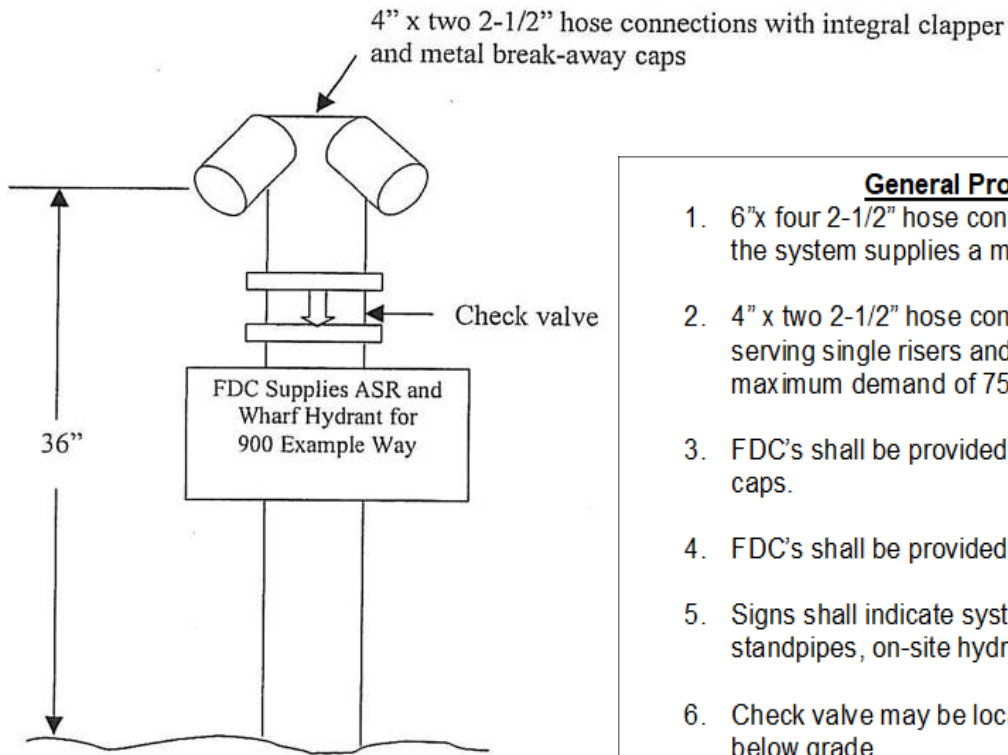
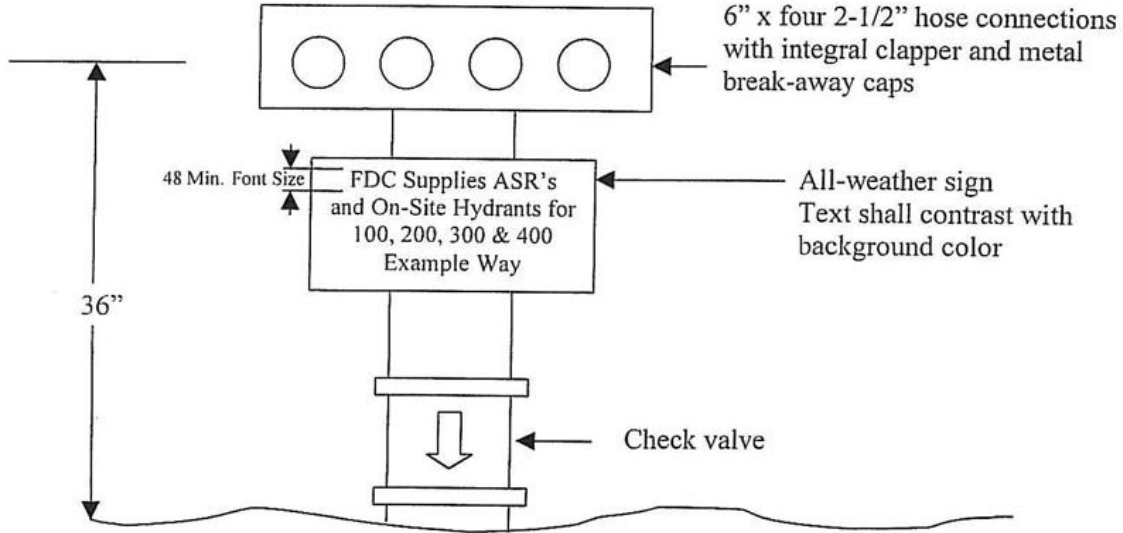

General Provisions

1. 6" x four 2-1/2" hose connections are required when the system supplies a minimum 6" UG supply.
2. 4" x two 2-1/2" hose connections are adequate for serving single risers and wharf hydrants with a maximum demand of 750 gpm.
3. FDC's shall be provided with metal break-away caps.
4. FDC's shall be provided with all-weather signs.
5. Signs shall indicate systems served (i.e. ASR's, standpipes, on-site hydrants, wharf hydrants.)
6. Check valve may be located in approved vault below grade.